

2s-158-6-100-AAC Datasheet

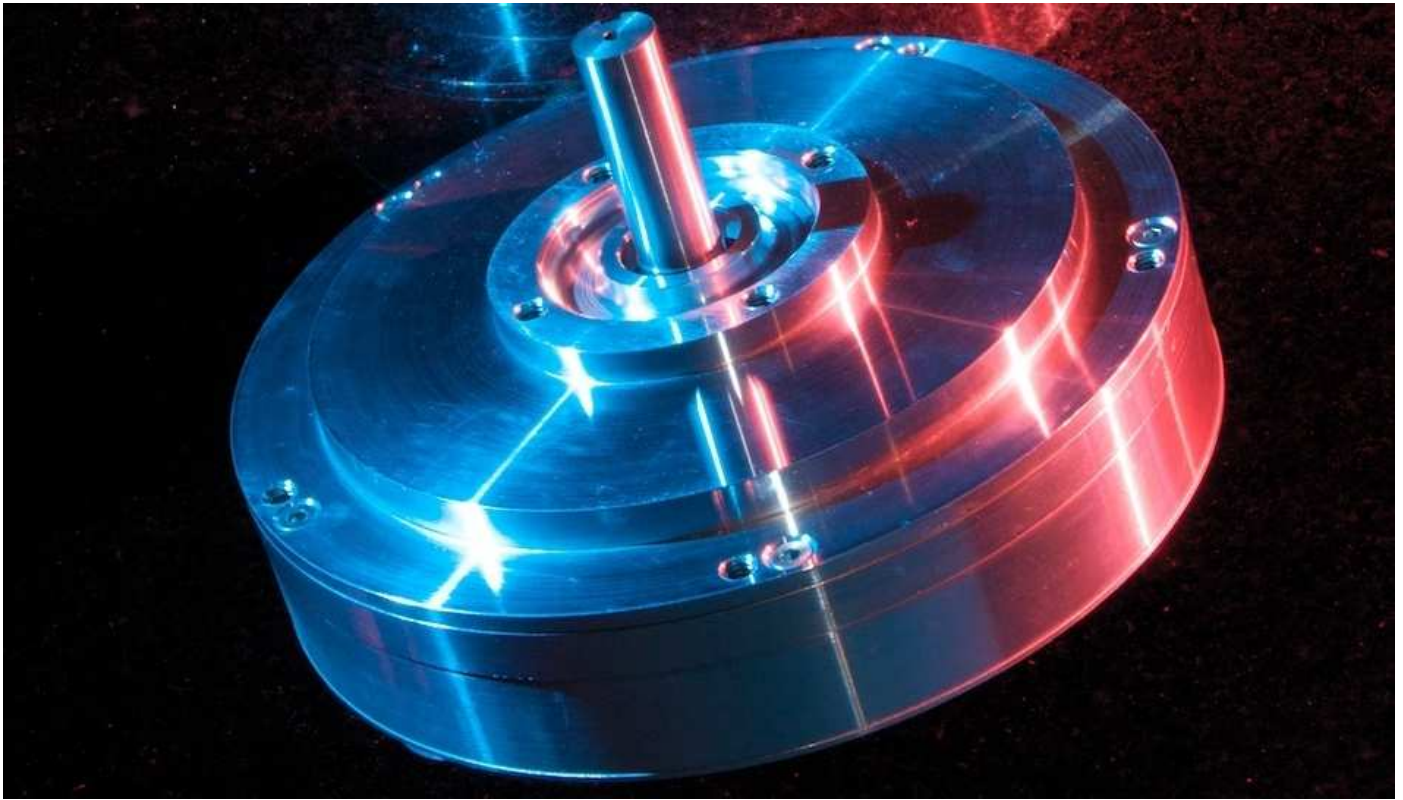

Rating

6.9 KW at 4,950 RPM

The 2s-158-6-100-AAC motor is a member of the 2s-158-6 family of SEMA motors and generators. It incorporates advanced air cooling techniques to achieve even higher specific power than other members of the 2s-158-6 family, which already demonstrate very high specific power. Similar motors in the 2s-158-6 SEMA family are available with different voltage and current requirements, and with different cooling options.

2s-158-6-100-ACC Parameters

Parameter	Symbol	Value	
Continuous Ratings 25°C ambient air 70 CFM			
Bus Voltage ¹	V_{bus}	~770 V _{DC}	
Speed	S	4,950 RPM	
Torque	T_c	13.2 N·m	9.7 lbf·ft
Current	I_c	8.6 A _{RMS}	
Power	P_{out}	6.9 KW	9.2 HP
Peak Ratings ²			
Torque	T_c	66.1 N·m	48.7 lbf·ft
Current	I_c	43.1 A _{RMS}	
Power	P_{out}	34.25 KW	45.9 HP
Motor Constants			
Torque Constant ³	K_T	1.66 N·m/A _{rms}	1.22 lbf·ft/A _{rms}
Torque Constant ⁴	K_T	1.53 N·m/A _{rms}	1.12 lbf·ft/A _{rms}
Voltage Constant (phase-phase) ³	K_E	100.3 V _{rms} /krpm	
Voltage Constant (phase-phase) ⁴	K_E	92.4 V _{rms} /krpm	
Electrical			
Resistance (phase-phase) ³	R	2.76 Ω	
Inductance (phase-phase)	L	998 μH	
Peak efficiency	e_{pk}	>92 %	
Thermal Limit			
Max. Thermocouple Temperature ⁵	T_{max_tc}	135 °C	275 °F
Mechanical			
Inertia (rotating components)	J_r	104 kg·cm ²	1.47 ozf·in·s ²
Mass	m	~5.53 kg	~12.2 lb
Pole Pairs	pp	6	
Motor diameter	AC	~220 mm	~8.66 in.
Motor length (not including shaft)	l	~71.7 mm	~2.82 in.

¹Minimum bus voltage controller dependant

²Peak values highly time dependent. 5X rated values shown - 10x is achievable.

³At 21°C

⁴With 100°C magnets.

⁵Never exceed this value.

Mechanical Drawings

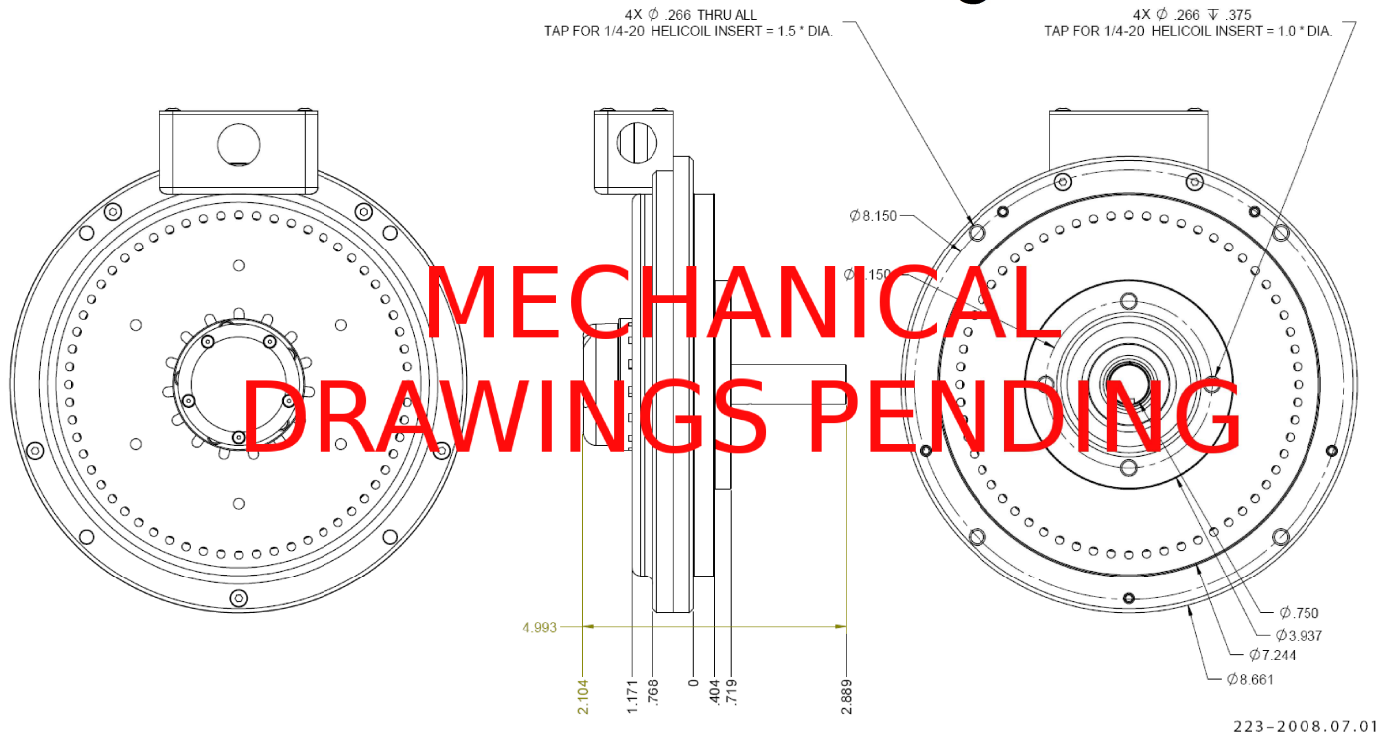

Efficiency Map

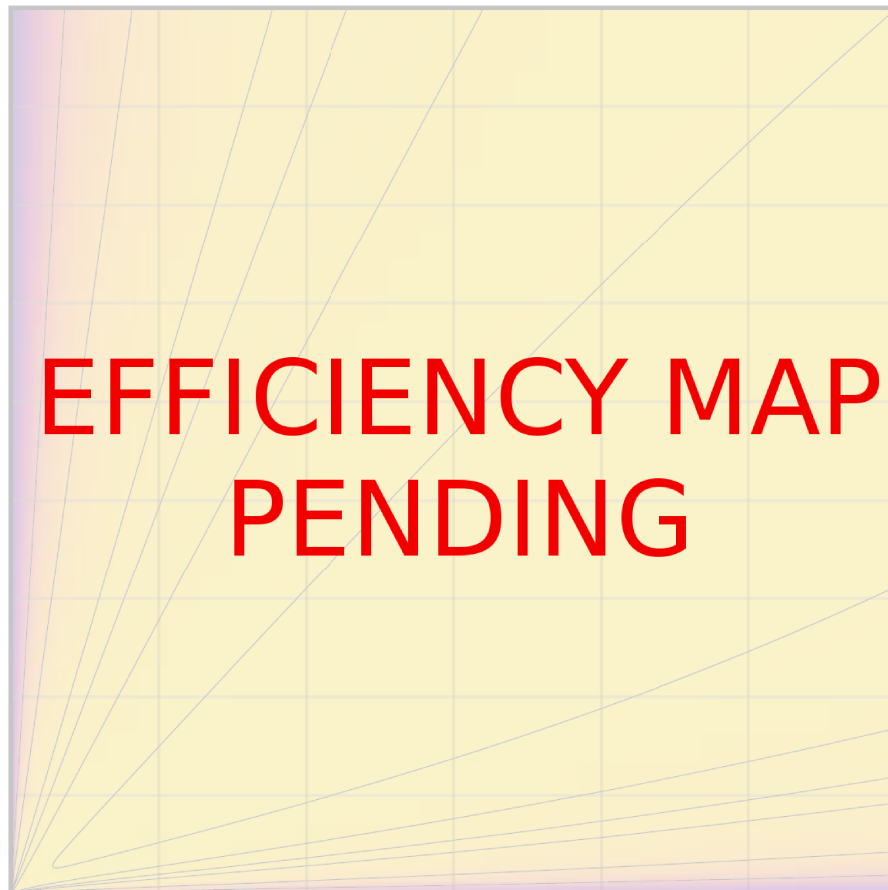

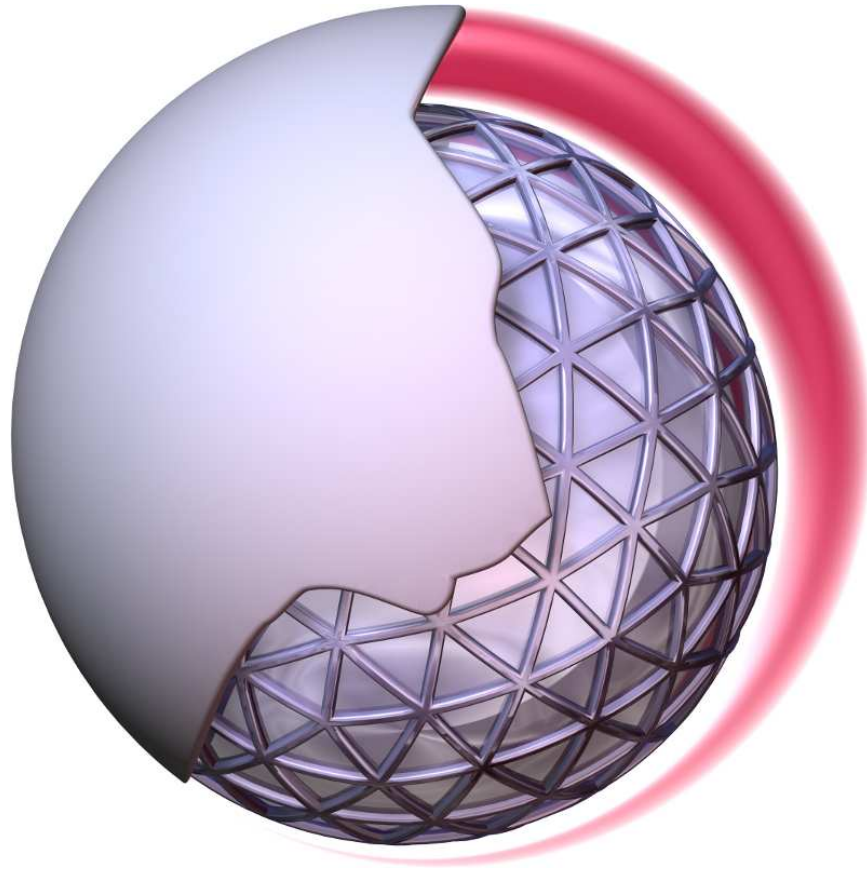

Kinetic Art & Technology

9540 Highway 150

PO Box 250

Greenville, IN 47124-0250 U.S.A.

+1 (812) 923-7474

www.katech.com

DISCLAIMER

Kinetic Art & Technology, Lynx Motion Technology and their licensees reserve the right to make changes without further notice to any product described herein to improve reliability, function or design. No information contained in these specifications convey a grant of any license, patent rights, or the rights of others. These specifications do not expand upon terms and conditions of sale of products described herein.